

298 x 298 x 121 mm

950 ml soap, 950 ml disinfectant, 950 ml lotion

- Combination consisting of a liquid soap-, disinfectant- and lotion dispenser in robust, germ-reducing and easy-care stainless steel (AISI 316L).
- All-stainless steel housing; all corners fully welded, visible surfaces satin finished and brushed.
Further available surfaces: see below.
- Soap or lotion dispenser with one-hand operated and non-drip soap or lotion pump.
Designed for standard 950 ml disposable bottles of liquid soap or lotion. Also refillable with large container using the plug-in tank as an option.
- Disinfectant dispenser with one-hand operated disinfectant pump with 950 ml tank arranged in the middle. Designed for standard disinfectants. Note: Not approved for medical areas.
- Inspection slots to indicate fill level.
- Accessible for refilling through lockable, hinged housing.
- Keyed alike cylinder lock in corrosion-resistant zinc die-casting.
- Wear parts can be replaced as modules.
- Mounting: With four screws through key holes and one optional anti-theft hole in the back wall.
- Delivery includes fixing material, first fill with soap and lotion.
- Weight, including single package: 5.3 kg



Suggested text for specifications:

Combination consisting of a liquid soap, disinfectant and lotion dispenser in stainless steel (AISI 316L) for surface mounting. All-stainless steel housing; all corners fully welded, visible surfaces satin finished and brushed. Soap or lotion dispenser with one-hand operated and non-drip soap or lotion pump. Designed for standard 950 ml disposable bottles of liquid soap or lotion. Disinfectant dispenser with one-hand operated disinfectant pump with 950 ml tank arranged in the middle. Designed for standard disinfectants. Inspection slots to indicate fill level. Accessible for refilling through lockable, hinged housing. Keyed alike cylinder lock in corrosion-resistant zinc die-casting. Delivery includes fixing material, first fill with soap and lotion.

Dimensions: 298 x 298 x 121 mm

Article No. WP575

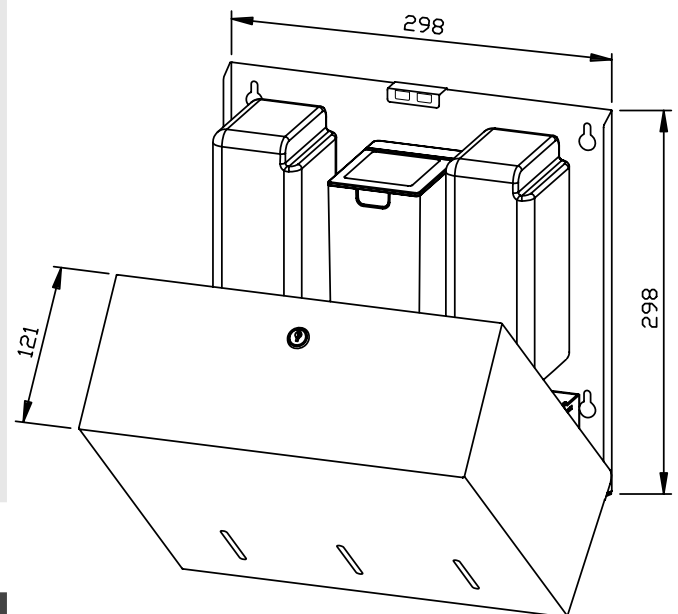

| Options | ID No. |
|-----------------------------------|---------|
| Plug-in tank | 937 201 |
| Available surfaces | ID No. |
| satin finished (standard) | 727 730 |
| highly polished | 731 730 |
| (coloured) plastic powder-coating | 728 730 |

Ernst Wagner GmbH & Co. KG

Ernst-Abbe-Straße 21 · D-72770 Reutlingen · Tel.: +49712151539-0 · Fax: -20
info@wagner-ewar.de · www.wagner-ewar.de